

Hydraulic Clamp

T-Slot Manual-Slide

Model **GBB**

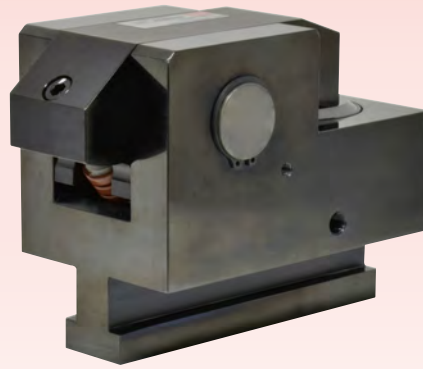

Suitable for Non-Standardized Mold Widths

Single Hydraulic Circuit with Basic and Simple Circuit Structure
We offer a wide range of options to meet your needs.

● Action Description

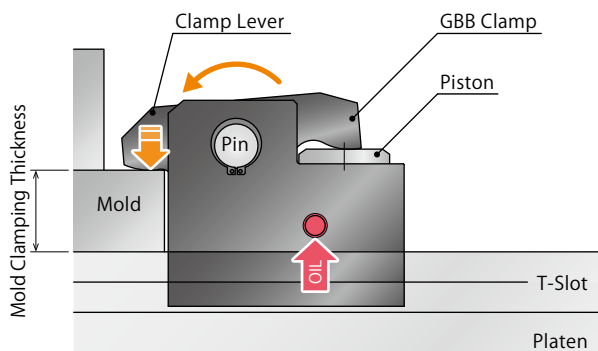

Locked State

When hydraulic pressure is supplied, the piston lifts up, and the clamp lever pivots on the pin and locks the mold.

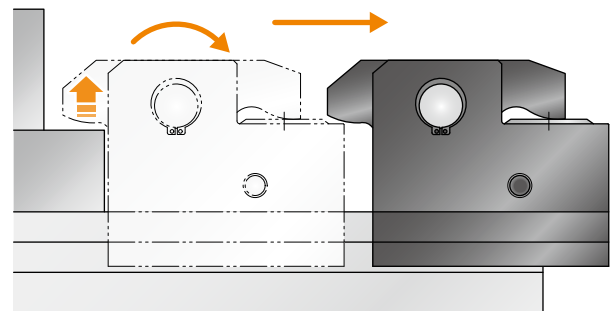

Released State

When hydraulic pressure is released, the piston descends with built-in spring force, and the clamp lever becomes released state with the lever return spring. GBB clamp is able to slide in the T-slot.

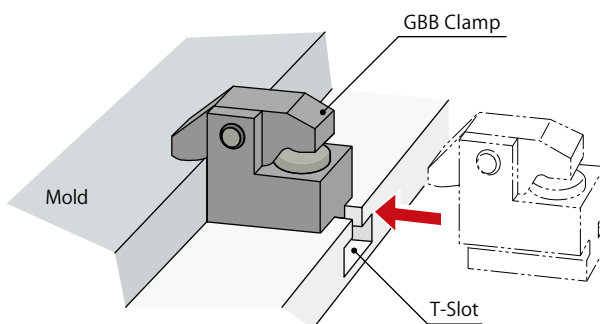

※ We provide GBB clamp according to the mold clamping thickness and T-slot dimension. Please refer to the external dimensions for detail.

System Structure Example

The basic structure with GBB clamp that is slid manually in the T-slot.

This system is able to control one stationary platen circuit and two movable platen circuits with a three-circuit hydraulic unit.

Hydraulic Clamp : GBB Clamp

Hydraulic Unit : CP□□ Unit

Stationary Platen

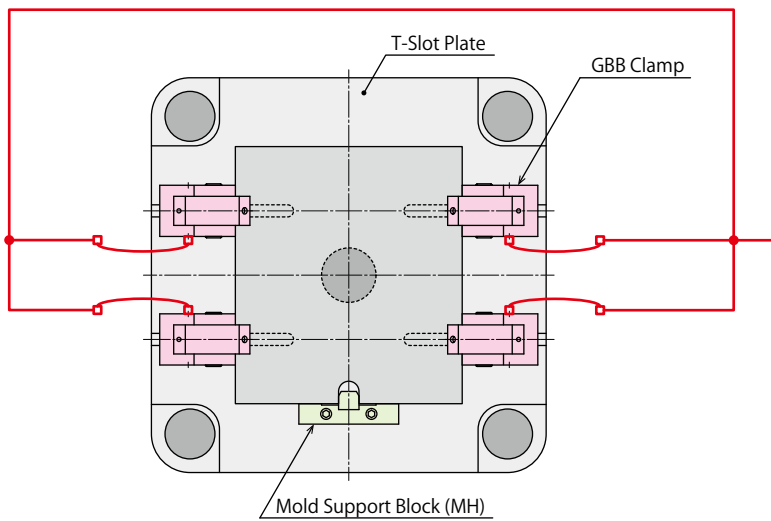

Movable Platen

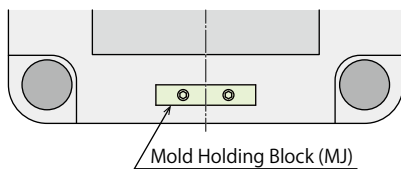
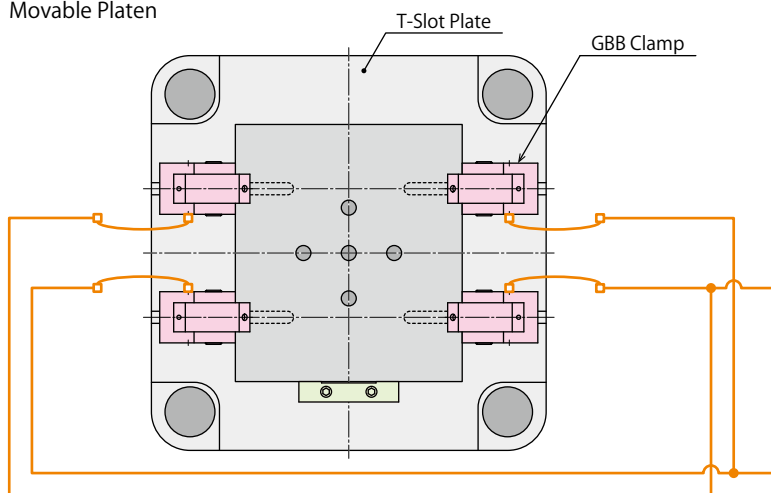

- Stationary Platen Hydraulic Circuit
- Movable Platen Hydraulic Circuit
- Air Circuit
- Electrical Circuit

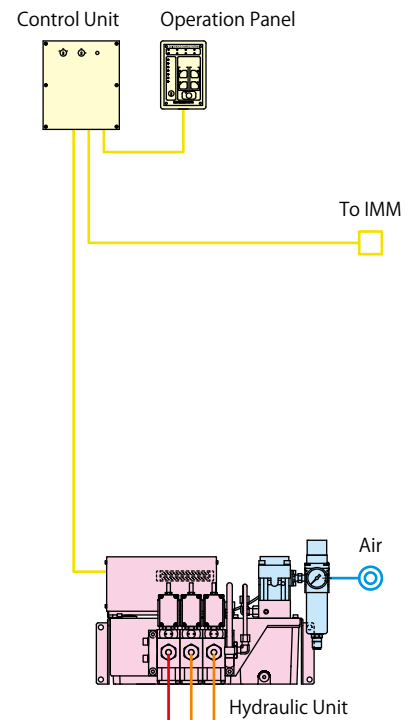

Model No. Indication

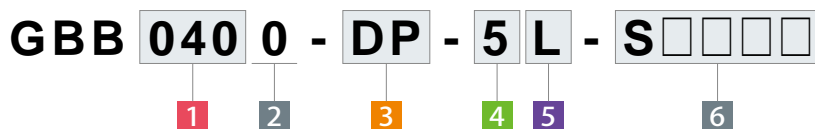

1 Clamping Force

- | | |
|-----------------------------------|------------------------------------|
| 010 : Clamping Force= 10kN | 100 : Clamping Force= 100kN |
| 016 : Clamping Force= 16kN | 160 : Clamping Force= 160kN |
| 025 : Clamping Force= 25kN | 250 : Clamping Force= 250kN |
| 040 : Clamping Force= 40kN | 400 : Clamping Force= 400kN |
| 063 : Clamping Force= 63kN | 500 : Clamping Force= 500kN |

2 Design No.

0 : Revision Number

3 Option

※ Please contact us for specifications/external dimensions.

- C1** : With Lock Confirmation Proximity Switch (GBB0400 or larger)
- C2** : With Lock Confirmation Proximity Switch/Cover (GBB0400 or larger)
- C3** : With Tapped Hole for Mounting Lock Confirmation Proximity Switch (GBB0400 or larger)
- D** : With Handle (GBB0630 or larger)
- E** : Reinforced Body
- H** : Extra Height Body (When h dimension is more than max. h dimension shown in the external dimension.)
- J** : Low Lever (When h dimension is less than min. h dimension shown in the external dimension.)
- K** : Rear Port
- L**□ : Wide Lever (For U-Cut of Mold) ※¹
- M**□ : For Mold with Notch
- N** : NPT Port ※²
- P** : With Mold Confirmation Proximity Switch
- R** : Longer D Dimension of T-Leg
- T** : T-Slot Locking
- U** : With Grease Nipple (Standard Option for GBB4000/GBB5000)
- V** : High Temperature (0~120°C)
- W** : With Check Valve (GBB1000 or larger)
- X** : With Cover

Notes

- ※1. Please indicate the U-cut dimension of the mold.
- ※2. Dimensions in the specification sheet and other documents are in inches.

4 Switch Load Voltage (Current)

- 1** : AC100V
- 2** : AC200V
- 5** : DC24V (5~40mA)

5 Switch Mounting Position

- L** : Left (Left Side as Seen from Clamp Back Side)
- R** : Right (Right Side as Seen from Clamp Back Side)

6 Production Number

This number represents the main specification of the clamp's T-slot stem and the clamping height. After the specification is confirmed, we will create a number.

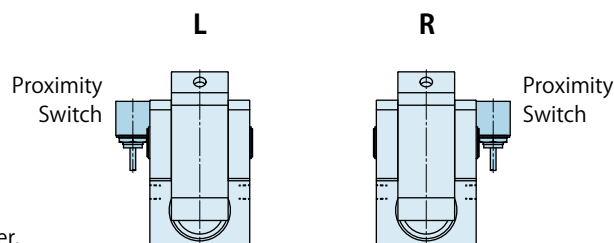

Specifications

Model No.	GBB0100	GBB0160	GBB0250	GBB0400	GBB0630	GBB1000	GBB1600	GBB2500	GBB4000	GBB5000	
Clamping Force	kN	10	16	25	40	63	100	160	250	400	500
Working Pressure	MPa	25 (For Rated Clamp Force)									
Withstanding Pressure	MPa	37									
Full Stroke	mm	6	7	7	7	8	8	8	8	8	8
Clamp Stroke	mm	3	3.5	3.5	3.5	4	4	4	4	4	4
Extra Stroke	mm	3	3.5	3.5	3.5	4	4	4	4	4	4
Cylinder Capacity (At Full Stroke)	cm ³	2.5	4.6	7.2	11.5	20.6	33.6	53.8	83.8	130.8	166.0
Operating Temperature ^{※3} °C		0~70 (High temperature option is available for 0~120°C)									
Use Frequency ^{※4}		Less than 20 Cycles / Day [※]									
Pressurizing Agent ^{※5 ※6 ※7}		General Hydraulic Oil Equivalent to ISO-VG-32									
Min. T-Slot Width a (JIS) ^{※8} mm		10	12	14	18	22	24	28	36	36	36 (2 T-Legs)
Max. T-Slot Width a (JIS) ^{※8} mm		20	24	32	42	42	54	54	54	54	42 (2 T-Legs)

Notes

- ※3. Option V: High Temperature (0~120°C) is for operating in temperatures of 70°C or more.
- ※4. Please contact us for more frequent use.
- ※5. Please contact us for fluids other than those mentioned on the list.
- ※6. If hydraulic viscosity is higher than specified, action time will be longer.
- ※7. If using it at low temperature, action time will be longer because the viscosity of hydraulic oil becomes higher.
- ※8. It shows reference dimensions. The dimension may differ from specification depending on T-slot (T-leg) dimension, dimension of clamp cylinder that sticks out of T-slot during lock action, or body material.

Option

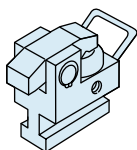

With Handle (GBB0630 or larger)
Model **GBB-D**

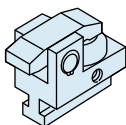

Reinforced Body
Model **GBB-E**

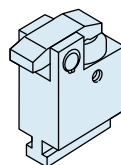

Extra Height Body
Model **GBB-H**

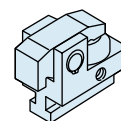

Low Lever
Model **GBB-J**

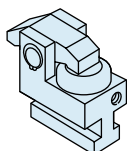

Rear Port
Model **GBB-K**

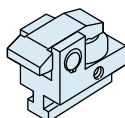

Wide Lever (For U-Cut of Mold)
Model **GBB-L** □

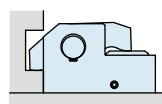

For Mold with Notch
Model **GBB-M** □

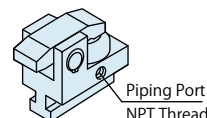

NPT Port
Model **GBB-N**

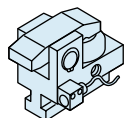

With Mold Confirmation Proximity Switch
Model **GBB-P**

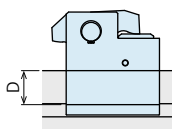

Longer D-Dimension of T-Leg
Model **GBB-R**

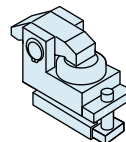

T-Slot Locking
Model **GBB-T**

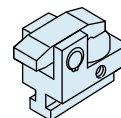

High Temperature 0 ~ 120 °C
Model **GBB-V**

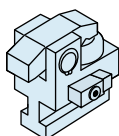

With Check Valve (GBB1000 or larger)
Model **GBB-W**

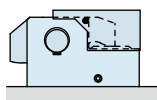

With Cover
Model **GBB-X**

With Lock Confirmation Proximity Switch

Model **GBB-C** □

With Grease Nipple
Model **GBB-U**

Note:

1. Specifications/external dimensions for these options are different from standard model. Please contact us for further information.

External Dimensions

※ This drawing shows GBB0100~GBB2500 standard model.
Contact us for external dimensions for options.

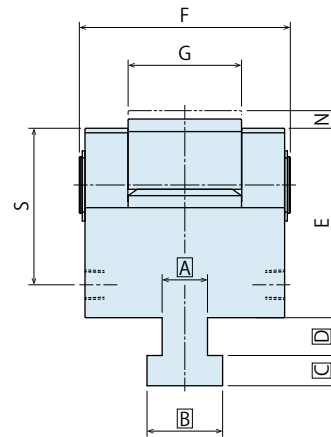
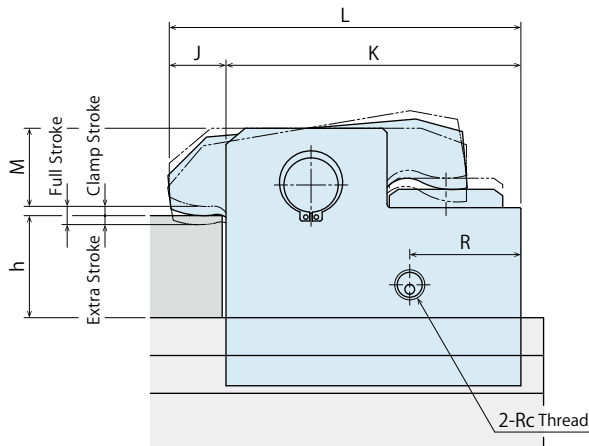

※ This drawing shows GBB4000 standard model.
Contact us for external dimensions for options.

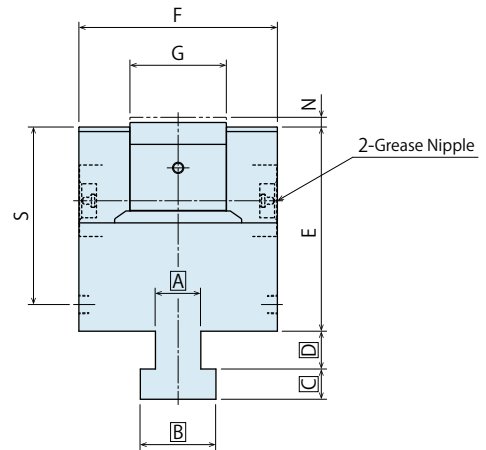
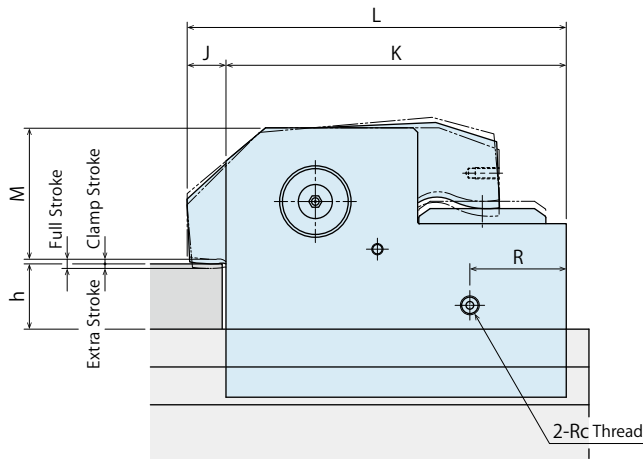

※ Only T-leg part of GBB5000 is different from GBB4000. GBB5000 has two T-legs.
Contact us for external dimensions for options.

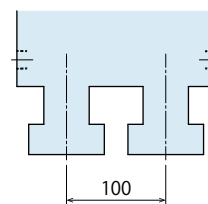

Notes

1. Do not exceed the clamping force on the specification.
2. Specifications/Contents in this catalog are subject to change without prior notice. Ask for the approval drawing before deciding to purchase.

T-Slot Dimensions

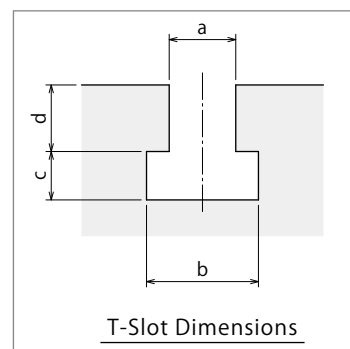

External Dimensions

(mm)

Model No.	GBB0100	GBB0160	GBB0250	GBB0400	GBB0630	GBB1000	GBB1600	GBB2500	GBB4000	GBB5000
Full Stroke	6	7	7	7	8	8	8	8	8	8
Clamp Stroke	3	3.5	3.5	3.5	4	4	4	4	4	4
Extra Stroke	3	3.5	3.5	3.5	4	4	4	4	4	4
min. E	42.5	49	58	66	81	105.5	122.5	144.5	177.5	202.5
F	43	53	63	73	93	103	124	152	175	200
G	20	26	32	38	50	53	60	73	85	100
J	15	17	19	22	25	30	30	30	35	37
K	58	70	84	105.5	130	159	199	240	300	340
L	73	87	103	127.5	155	189	229	270	335	377
M (h)	21.5 (20)	27.5 (20)	31.5 (25)	39.5 (25)	49.5 (30)	64 (40)	81 (40)	98 (45)	126 (50)	141 (60)
	16.5 (25)	22.5 (25)	26.5 (30)	34.5 (30)	44.5 (35)	59 (45)	76 (45)	93 (50)	121 (55)	136 (65)
	16.5 (30)	17.5 (30)	21.5 (35)	29.5 (35)	39.5 (40)	54 (50)	71 (50)	88 (55)	116 (60)	131 (70)
	16.5 (35)	17.5 (35)	21.5 (40)	29.5 (40)	34.5 (45)	49 (55)	66 (55)	83 (60)	111 (65)	126 (75)
	16.5 (40)	17.5 (40)	21.5 (45)	29.5 (45)	29.5 (50)	44 (60)	61 (60)	78 (65)	106 (70)	121 (80)
	-	-	21.5 (50)	29.5 (50)	29.5 (55)	44 (65)	61 (65)	78 (70)	106 (75)	116 (85)
	-	-	-	-	29.5 (60)	44 (70)	61 (70)	78 (75)	106 (80)	-
	-	-	-	-	-	-	61 (75)	78 (80)	106 (85)	-
N	5.5	6.5	6.5	6.5	8	8	9	9.5	9.5	10
R	27	27	37	42	49	68	73	69.5	85	90
S	33.5	40	46	54	69	93.5	108.5	127.5	156.5	174.5
Rc	Rc1/8	Rc1/8	Rc1/4	Rc1/4	Rc1/4	Rc1/4	Rc1/4	Rc1/4	Rc3/8	Rc3/8
min. h	20	20	25	25	30	40	40	45	50	60
max. h	40	40	50	50	60	70	80	80	85	85

Notes

1. If you would like to change the ratio of clamp stroke and extra stroke, please contact us.
2. A B C D dimensions are determined by Kosmek according to the T-slot dimensions.
3. When making an order, please indicate a, b, c, d dimension of T-slot and h dimensions of mold clamping thickness.

GBB Clamp The Allowable Protrusion Amount of Cylinder

(mm)

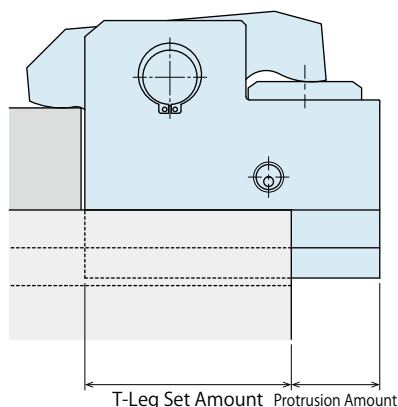

Model No.	Min. T-Leg Set Amount	Allowable Protrusion Amount
GBB0100	40.5	17.5
GBB0160	49.0	21.0
GBB0250	59.0	25.0
GBB0400	73.5	32.0
GBB0630	91.0	39.0
GBB1000	114.0	45.0
GBB1600	142.0	57.0
GBB2500	170.5	69.5
GBB4000	-	-
GBB5000	-	-

Note:

1. The dimensions on the list are for reference.
The dimensions may differ from specification depending on T-slot (T-leg) dimension or body material.

Sales Offices

Sales Offices across the World

Japan	TEL. +81-78-991-5162	FAX. +81-78-991-8787
Overseas Sales	KOSMEK LTD. 1-5, 2-chome, Murotani, Nishi-ku, Kobe-city, Hyogo, Japan 651-2241 〒651-2241 兵庫県神戸市西区室谷2丁目1番5号	
USA	TEL. +1-630-241-3465	FAX. +1-630-241-3834
KOSMEK (USA) LTD.	1441 Branding Avenue, Suite 110, Downers Grove, IL 60515 USA	
China	TEL.+86-21-54253000	FAX.+86-21-54253709
KOSMEK (CHINA) LTD. 考世美(上海)貿易有限公司	21/F, Orient International Technology Building, No.58, Xiangchen Rd, Pudong Shanghai 200122., P.R.China 中国上海市浦东新区向城路58号东方国际科技大厦21F室 200122	
Thailand	TEL. +66-2-715-3450	FAX. +66-2-715-3453
Thailand Representative Office	67 Soi 58, RAMA 9 Rd., Suanluang, Suanluang, Bangkok 10250, Thailand	
Taiwan (Taiwan Exclusive Distributor)	TEL. +886-2-82261860	FAX. +886-2-82261890
Full Life Trading Co., Ltd. 盈生貿易有限公司	16F-4, No.2, Jian Ba Rd., Zhonghe District, New Taipei City Taiwan 23511 台湾新北市中和區建八路2號 16F-4 (遠東世紀廣場)	
Philippines (Philippines Exclusive Distributor)	TEL.+63-2-310-7286	FAX. +63-2-310-7286
G.E.T. Inc, Phil.	Victoria Wave Special Economic Zone Mt. Apo Building, Brgy. 186, North Caloocan City, Metro Manila, Philippines 1427	
Europe (Europe Exclusive Distributor)	TEL. +43-463-287587-10	FAX. +43-463-287587-20
KOS-MECH GmbH	Schleppplatz 2 9020 Klagenfurt Austria	
Indonesia (Indonesia Exclusive Distributor)	TEL. +62-21-5818632	FAX. +62-21-5814857
P.T PANDU HYDRO PNEUMATICS	Ruko Green Garden Blok Z- II No.51 Rt.005 Rw.008 Kedoya Utara-Kebon Jeruk Jakarta Barat 11520 Indonesia	

Sales Offices in Japan

Head Office	TEL.078-991-5115	FA	 WAHLTEC [®] KNOWLEDGE TRUST SUCCESS
Osaka Sales Office	〒651-2241	兵庫県神戸市西区	
Overseas Sales			
Tokyo Sales Office	TEL.048-652-8839	FA	
	〒331-0815	埼玉県さいたま市	WAHLTEC GmbH Ravensburger Str. 14 88361 Altshausen T: +49 (7584) 9238883 F: +49 (7584) 9238887 www.wahltec.de
Nagoya Sales Office	TEL.0566-74-8778	FA	
	〒446-0076	愛知県安城市美園	
Fukuoka Sales Office	TEL.092-433-0424	FA	
	〒812-0006	福岡県福岡市博多	